

Electron Beam Welding of Pipe Branches



Dimensions and weights

- Outer diameter up to 1000 mm
- Wall thickness up to 50 mm
- Branch angle 30 ° bis 90 °
- Branch weight up to 5000 kg

Contacts

- Web: www.josch.net
- Mail: office@josch.net
- Fon: +49 34606 353-0

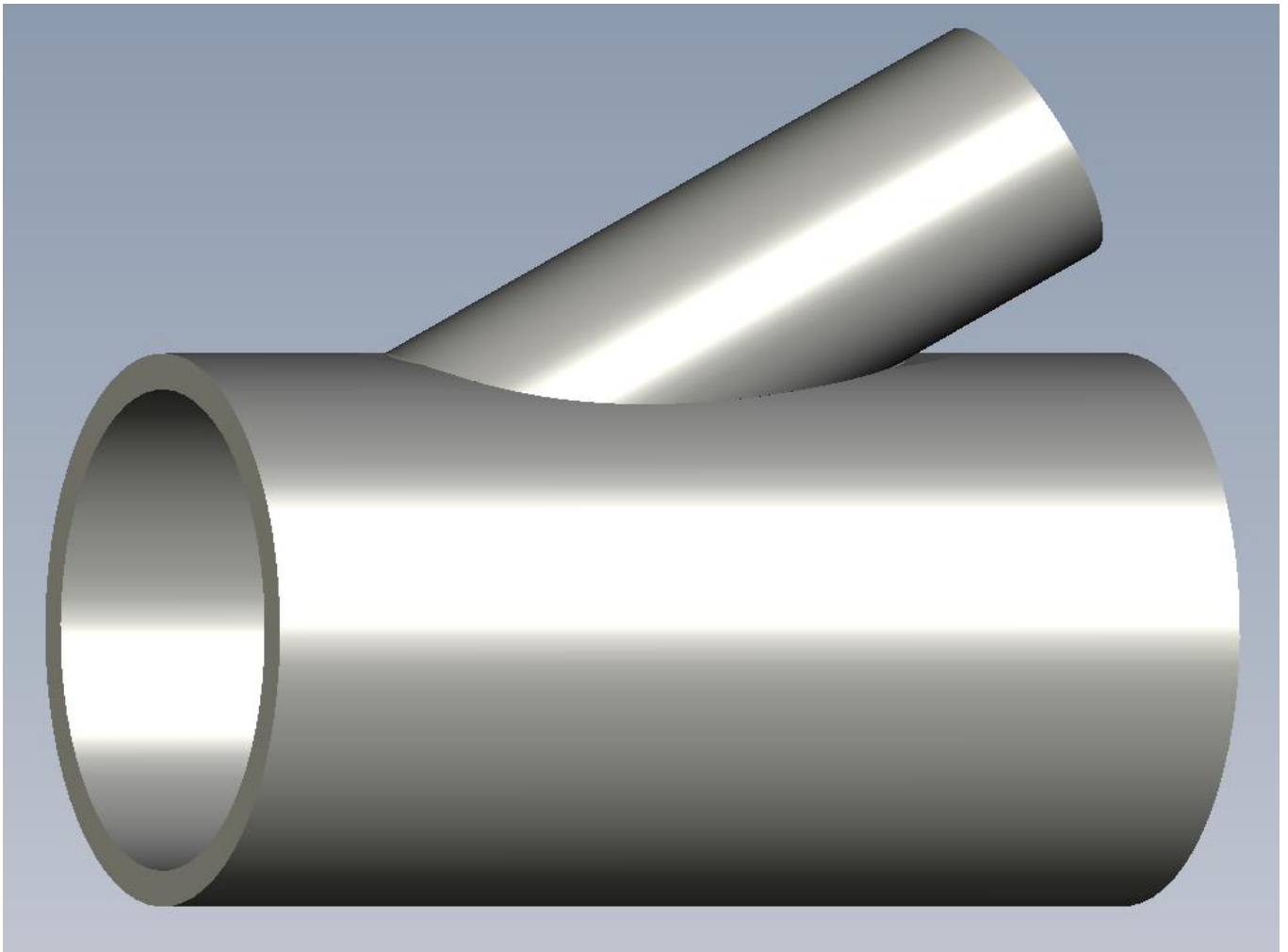

Our services

- Consulting for preparation of production
- Delivery of material (on demand)
- Mechanical treatment of the pipes
- Qualification of the welding process
- Electron beam welding of the branches
- Post welding heat treatment (if necessary)
- NDT testing and documentation

Suitable Materials

- Low and high alloyed steels
- Nickel based alloys
- Copper and copper alloys
- Aluminium alloys
- Titanium and titanium alloys
- Further materials on demand
- Material combinations

JOSCH – Electron Beam Welding – Electron Beam Hardening